

Data Sheet

Customer: C1A001151

Part No: CL-SFC506IR-830-01

Sample No: _____

Description: IR SMD

Item No: _____

Customer			
Check	Inspection	Approval	Date

CL			
Drawn	Check	Approval	Date
			2022/11/1

Features:

- . High radiant power and high radiant intensity.
- . Low forward voltage.
- . Good Reliability and Long Life
- . Soldering methods: reflow soldering
- . This product doesn't contain restriction substance, comply ROHS standard
- . Pb free

Applications

- . Remote Control.
- . Smoke detector
- . Infrared applications systems
- . Infrared remote control emission



Description

- . This infrared LED is a low power consumption diode in SMD package.
- . This model has the advantages of strong transmitting power and uniform light angle.
- . The device is spectrally matched with phototransistor, photodiode and infrared receiver module.

Package Dimensions in millimeters

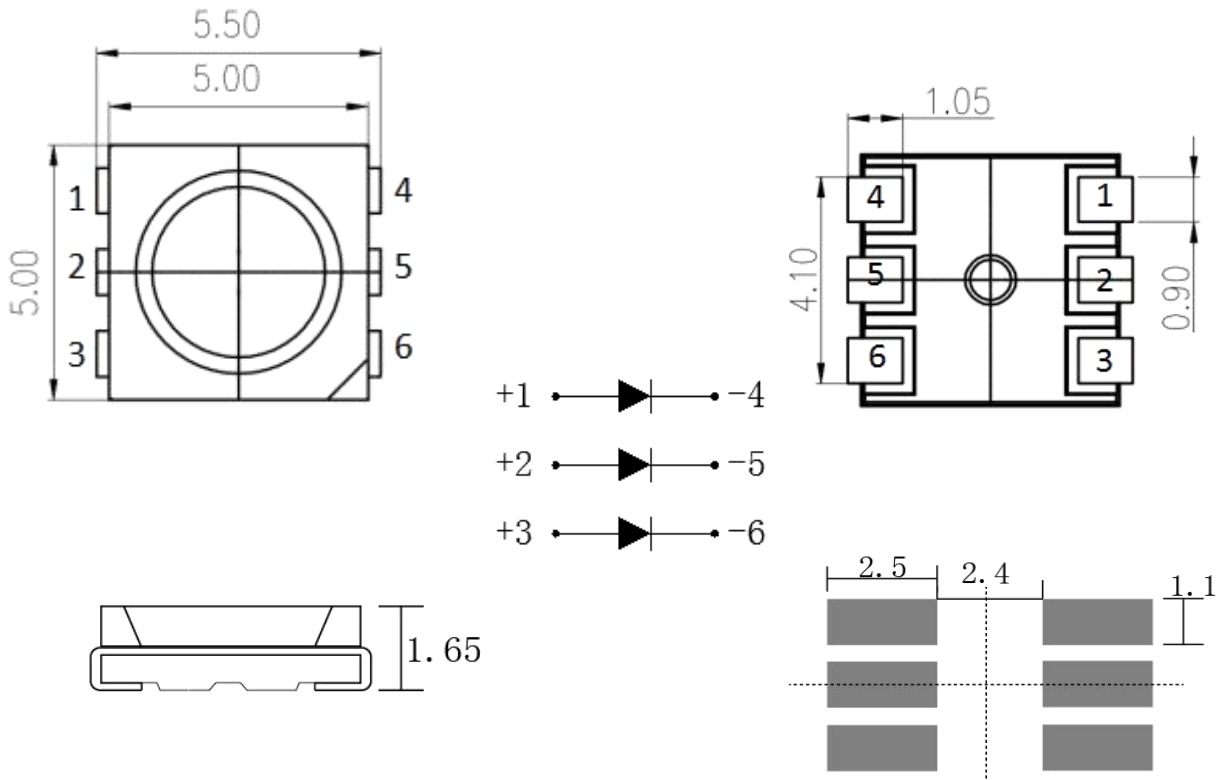

Notes:

1. All dimensions are in millimeters.
2. All dimension tolerance is $\pm 0.2\text{mm}$ unless otherwise noted.
3. Specifications are subject to change without notice

Selection Guide

Part No.	Chip Materials	Lens Type
CL-SFC506IR-830-01	AlGaAs/GaAs	Water clear

Electrical And Optical Characteristics (Ta=25°C)

Parameter	Symbol	Min	Typ.	Max	Units	Condition
Radiant Intensity	I _e	2	7	-	mW/sr	IF=20mA
Forward Voltage	V _F	1.2	1.7	-	V	IF=20mA
Reverse Current	I _R	-	-	10	uA	V _R =5V
Peak Wavelength	λ _p	820	830	840	nm	IF=20mA
Controlled Angle	2θ _{1/2}	-	120	-	deg	IF=20mA

Note:

1. 2θ_{1/2} is the angle from optical centerline where the luminous intensity is 2θ_{1/2} the optical centerline value.
2. the above luminous intensity measurement allowance tolerance ±10%

Absolute Maximum Ratings (Ta=25°C)

Parameter	Symbol	Ratings	Units	Notice
Continuous Forward Current	I _F	50	mA	--
Power Dissipation	P _D	90	mw	--
Reverse Voltage	V _R	5	V	--
Operating Temperature	T _{opr}	-20~+80	°C	--
Storage Temperature	T _{stg}	-40~+100	°C	--
Soldering Temperature	T _{sd}	260 (<10sec)	°C	--

Note:

1/10 Dut cycle,0.1ms pulse width.

Typical Optical-Electrical Characteristic Curves

Fig.1 Forward Current Vs Forward Voltage

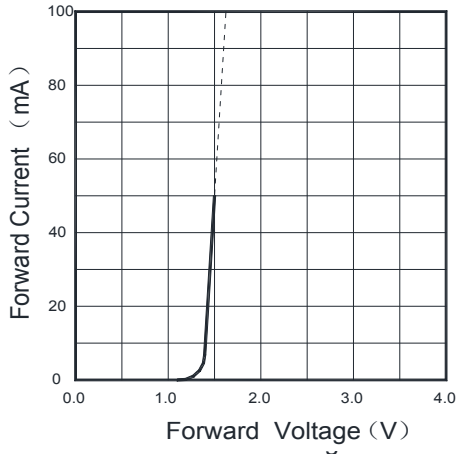

Fig.2 Relative Radiant Intensity Vs Forward Current

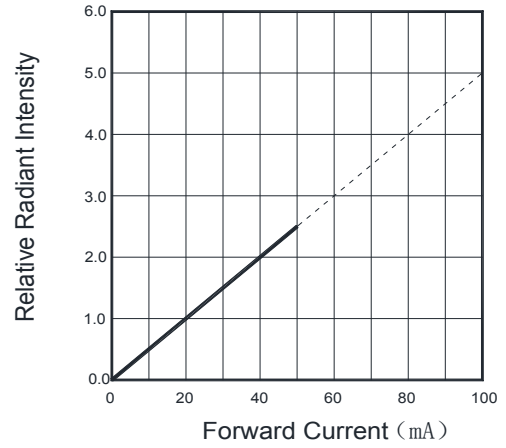

Fig.3 Relative Forward Voltage Vs Ambient Temperature

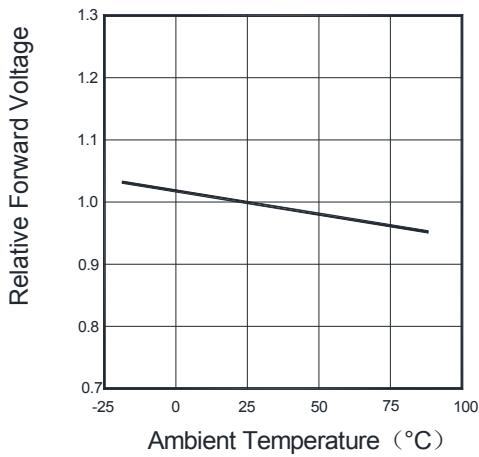

Fig.4 Relative Radiant Intensity Vs Ambient Temperature

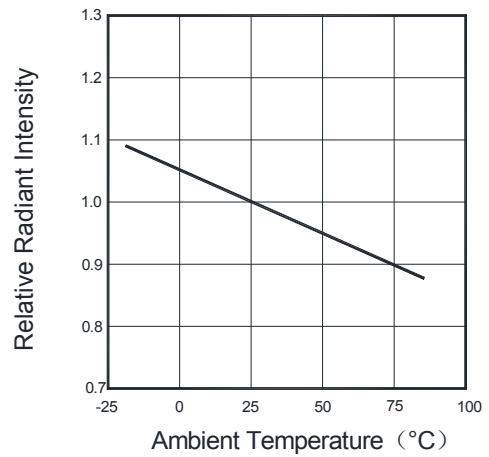

Fig.5 Spectral Distribution

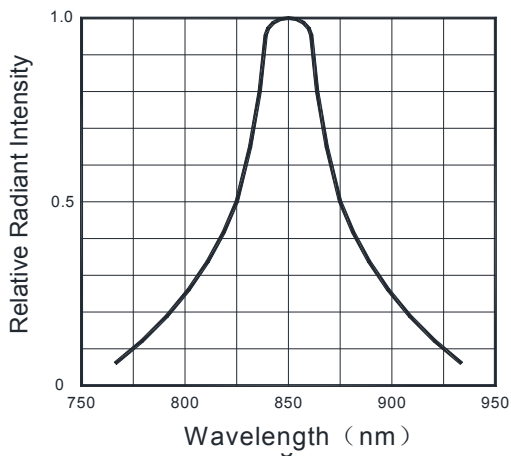
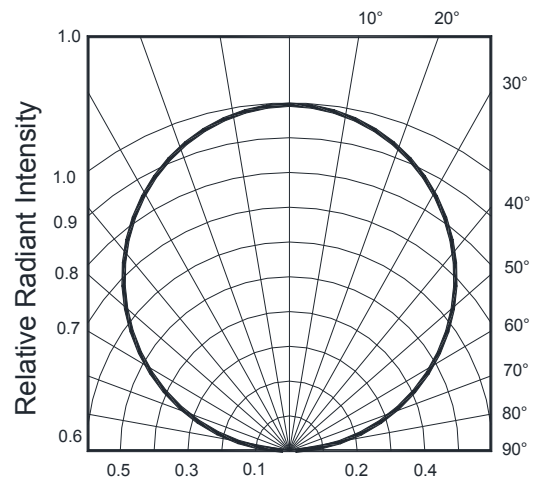

Fig.6 Radiant Diagram



Reliability Test Item And Condition

Test Item	Test Condition	Time	Quantity	Ac/Re
Life Test	Ta=25°C±5°C IF=20mA	1000H	22	0/1
High Temperature Life Test	Ta=85°C±5°C IF=20mA	1000H	22	0/1
Storage at High Temperature	Ta=100±5°C	1000H	22	0/1
Storage at Low Temperature	Ta=-40±5°C	1000H	22	0/1
Storage at High Temperature/High Humidity	Ta:85±5°C,RH:85±5%	1000H	22	0/1
Temperature cycle	100°C~25°C~-40°C~25°C (30min)(5min)(30min) (5min)	100 Cycles	22	0/1
Red ink	Ta=100±5°C	2H	22	0/1
Reflow soldering	Temp:260°C max T=10 sec	3 times	22	0/1

The technical information shown in the data sheets are limited to the typical characteristics and circuit examples of the referenced products.It does not constitute the warranting of industrial property nor the granting of any license.

SMT Reflow Soldering Instructions

1. The number of reflow soldering shall not exceed two times, and the time from the second processing to the first completion shall not exceed 168H
2. When soldering, do not put stress on the LEDs during heating.
3. Reflow temperature distribution (Acc. to J-STD-020D)

Profile Feature	Sn-Pb Eutectic Assembly		Pb-Free Assembly	
	Large Body	Small Body	Large Body	Small Body
Average ramp-up rate (TL to Tp)	3°C/second max.		3°C/second max.	
Preheat	100°C		150°C	
-Temperature Min(TSmin)	150°C		200°C	
-Temperature Max(TSmax)	60-120 seconds		60-180 seconds	
-Time(min to max)(ts)				
Tsmax to TL			3°C/second max.	
-Ramp-up Rate				
Time maintained above:	183°C		217°C	
-Temperature(TL)	60-150 seconds		60-150 seconds	
-Time(tL)				
Peak Temperature(Tp)	225+0/-5°C	240+0/-5°C	245+0/-5°C	260+0/-5°C
Time within 5°C of actual Peak Temperature(tp)	10-30 seconds	10-30 seconds	10-30 seconds	20-40 seconds
Ramp-down Rate	6°C/second max.		6°C/second max.	
Time 25°C to Peak Temperatur	6 minutes max.		8 minutes max.	

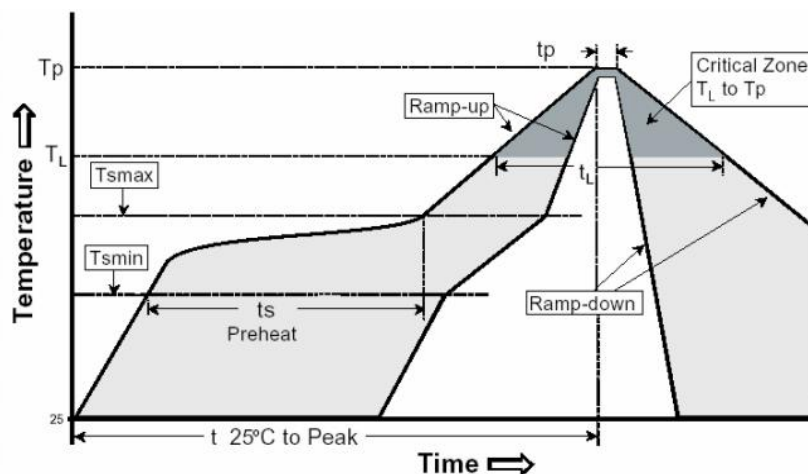

Soldering iron

1. When hand soldering, the temperature of the iron must be less than 350°C for 3 seconds
2. The hand solder should be done only one time

Repairing

Repair should not be done after the LEDs have been soldered. When repairing is unavoidable, a double-head soldering iron should be used (as below figure). It should be confirmed in advance whether the characteristics of LEDs will or will not be damaged by repairing.

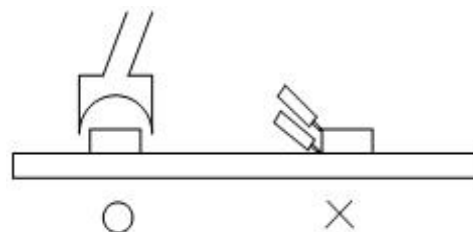

Storage

The package is sealed:

- 1.Recommended storage condition :At 5 °C~30°C and relative humidity 90% RH max.
- 2.It is recommended that SMD out of their original packaging are used within Three months.

The package is opened:

- 1.Completed within 24 hours.
- 2.Stored at5 °C~30°C and 60% RH or less.
- 3.LEDs stored more than 24 hours should be baked at about 65 °C±5 °C for at least 24 hours before solder assembly.

ESD

Static Electricity will damage the LED.

The following procedures may decrease the possibility of ESD damage.

- 1.All productive machinery and test instruments must be electrically grounded.
- 2.Use a conductive wrist band or anti-electostatic glove when handling these LEDs.
- 3.Manintain a humidity level of 50%RH or higher in production areas.
- 4.Use anti-static packaging for transport and storage.

Handling Precautions

- 1.Do not stack together assembled PCBs containing LEDs. Impact may scratch the silicone lens or damage.
- 2.Not available in the situation of acidity for PH.
- 3.Electrostatic sensitive device

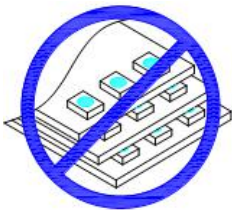

Carrier tape

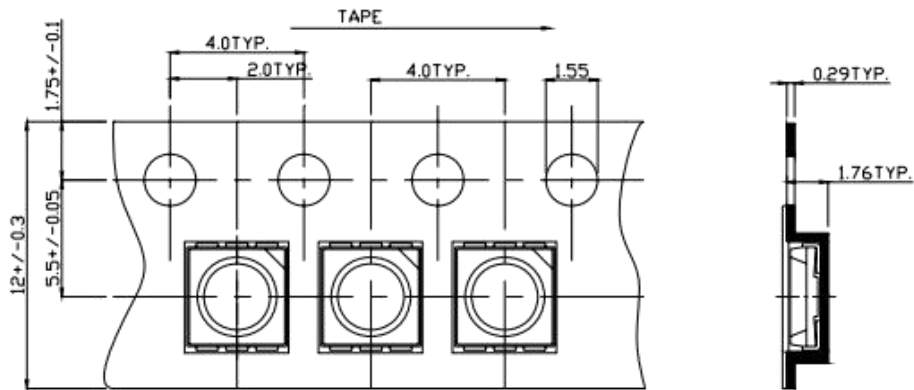

MPQ:1000PCS/Small reel

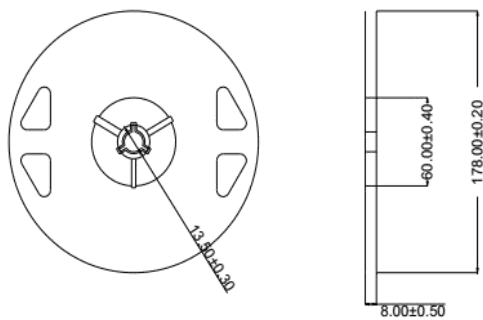

MPQ:5000PCS/Big reel

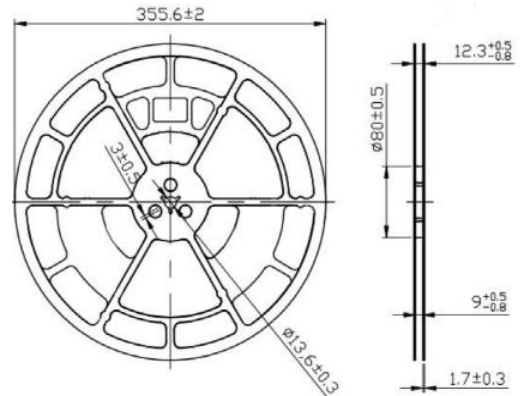

Moisture Resistant Packaging

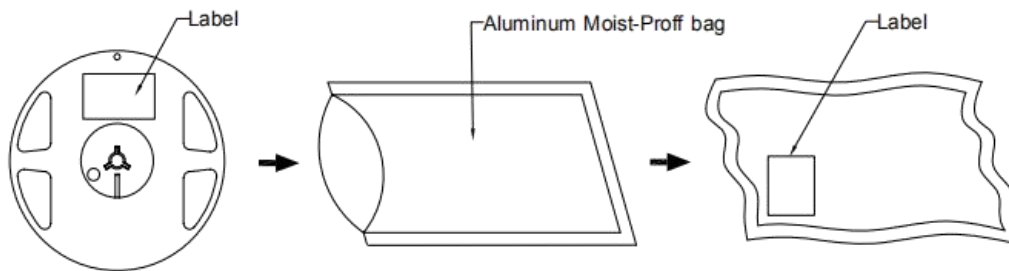

Cardboard Box

Maximum packing quantity (5 packs of material)

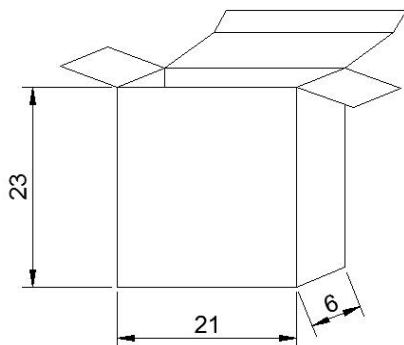

Maximum packing quantity (27 bags of material or 5 small boxes)

